

DRAWER BASE CABINET

CODE	ITEM	QTY
A	Right Left Side Panel	2
D	Bottom Panel	1
G	Shelf	1
H	Back Panel	1
J	Toe Kick Plate	1
K	Drawer Glide	6
M	Front Face	1
N	Drawer Head	3
S	Support Bracket	4
T	Rear Slide Bracket	6
V	Drawer Box	3

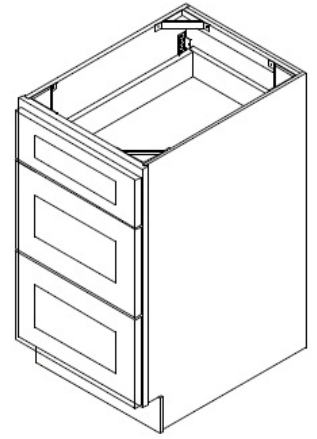

EASY ASSEMBLY METAL CLIP SYSTEM

- Align Clips ① and ②
- Slide ① into ②
- Insert locking screw into clip pair
- Tighten all screws

STEP 1

- Lay H flat; grooves facing upward
- Insert A into metal clips of H (refer to Metal Clip System)

STEP 2

- Slide D into grooves of A and H

STEP 3

- Attach M onto D and A (refer to Metal Clip System)
- Attach J onto bottom front of A using the Metal Clip System

STEP 4

- Place and screw S (plastic brackets) into corners of M, A, and H

STEP 5

- Screw both rear brackets T into the pre-drilled holes in H
- Install K by sliding into T and screwing into side of M

STEP 6

- Screw the drawer head N onto the drawer box V through the pre-drilled holes

end result

STEP 7

- Position drawer box over drawer glides
- Slide drawer glides into clips so that they click and attach, then close drawer